

# Inspection Report-D5-B+ D5-C-Left (return+desk)

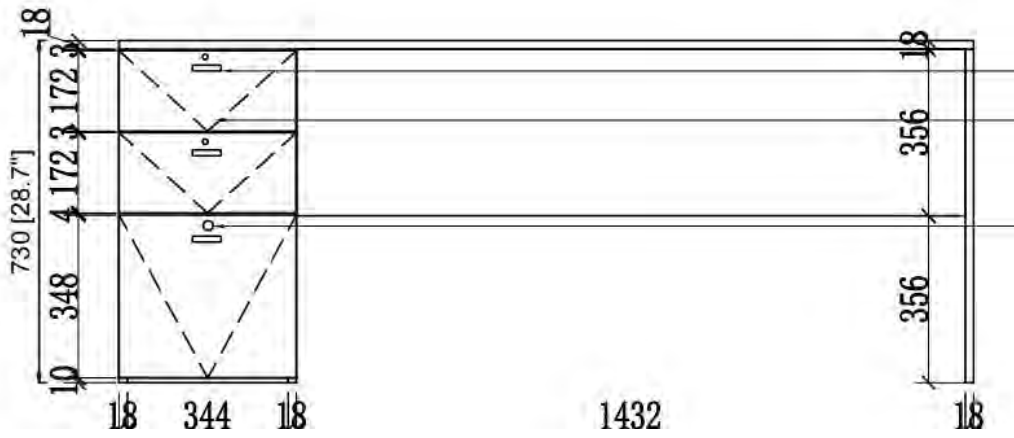

14:45

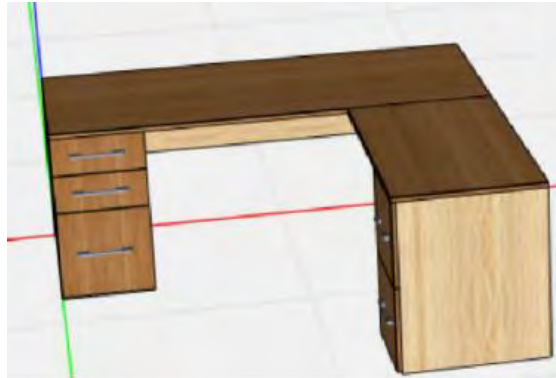
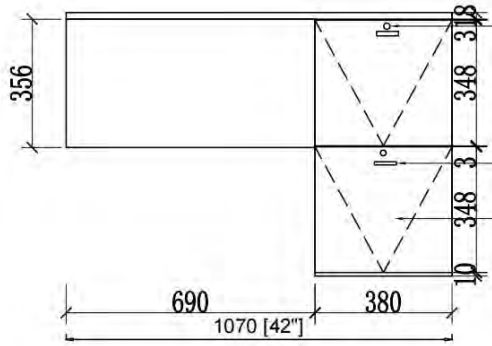

width of left return: 107cm



depth of return: 60cm



width of ped: 38cm



height: 73cm



# Inspection Report-D7A-Double Ped Desk

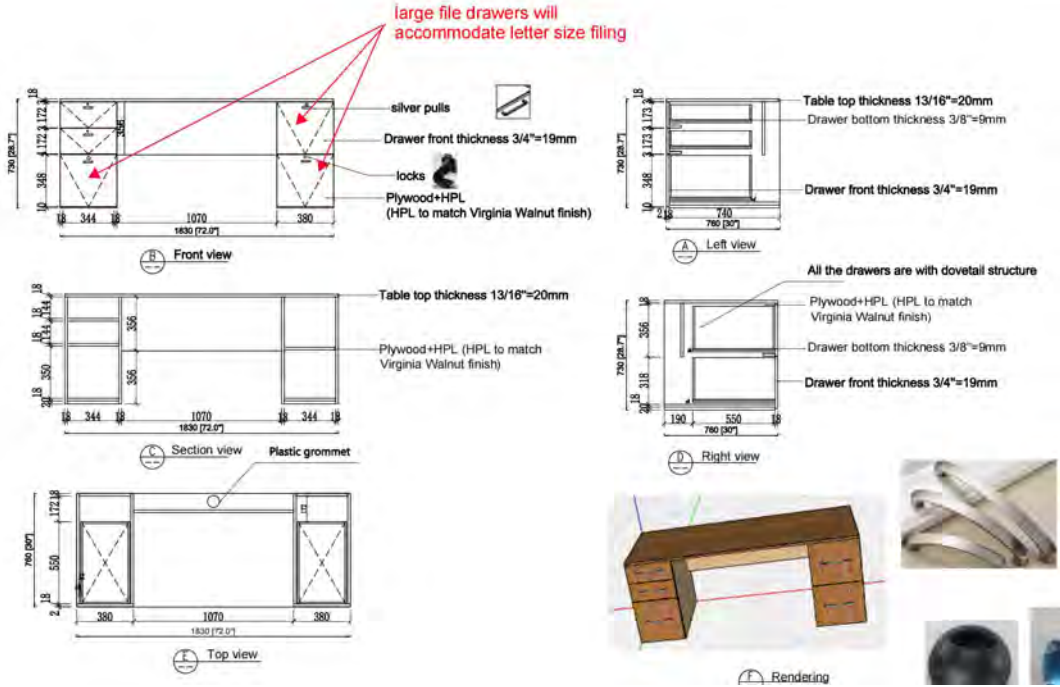



Depth of table top: 76cm

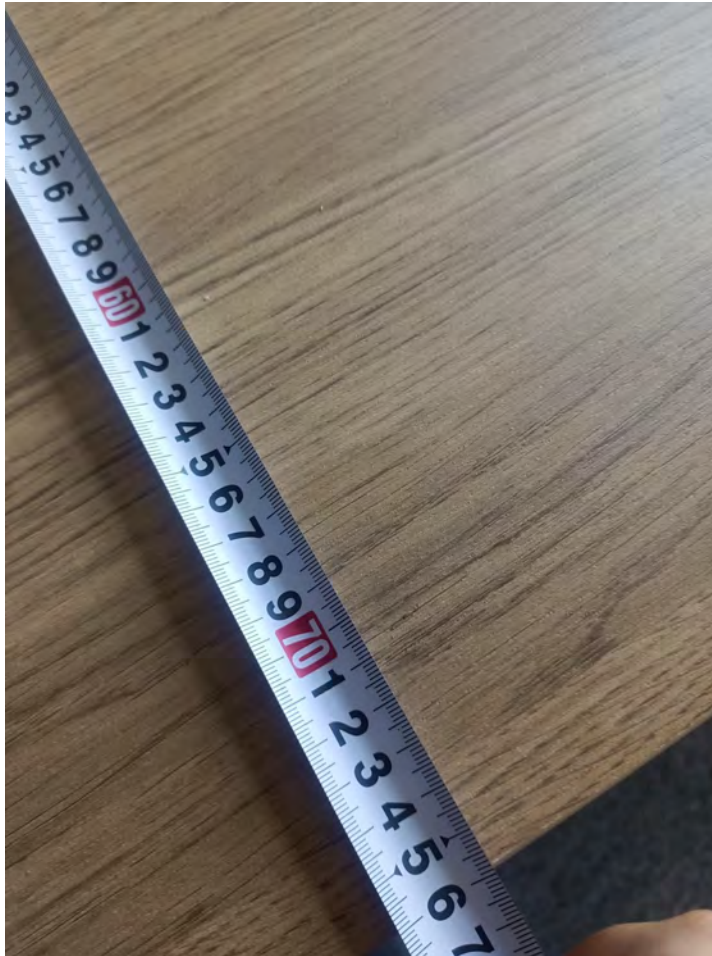

Width of table top: 183cm



width of ped: 38cm

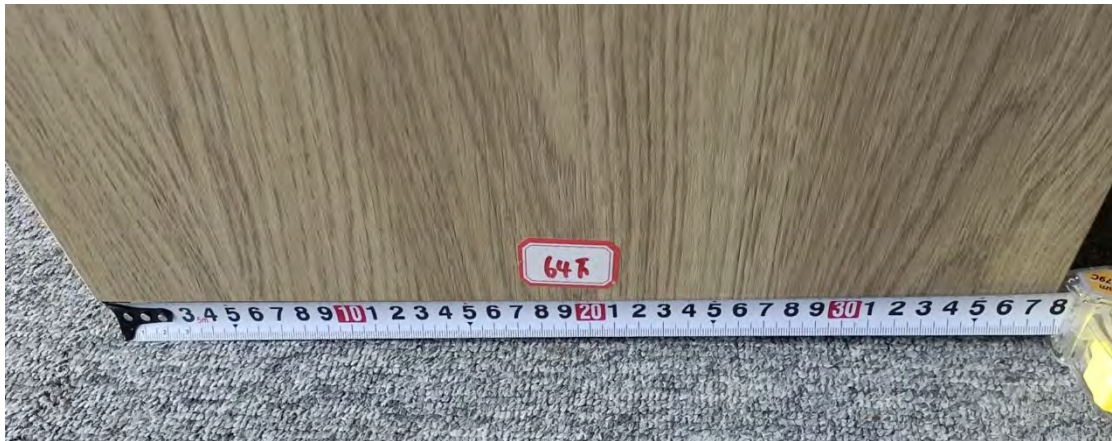

Height: 73cm



# Inspection Report-O1-ADA Table

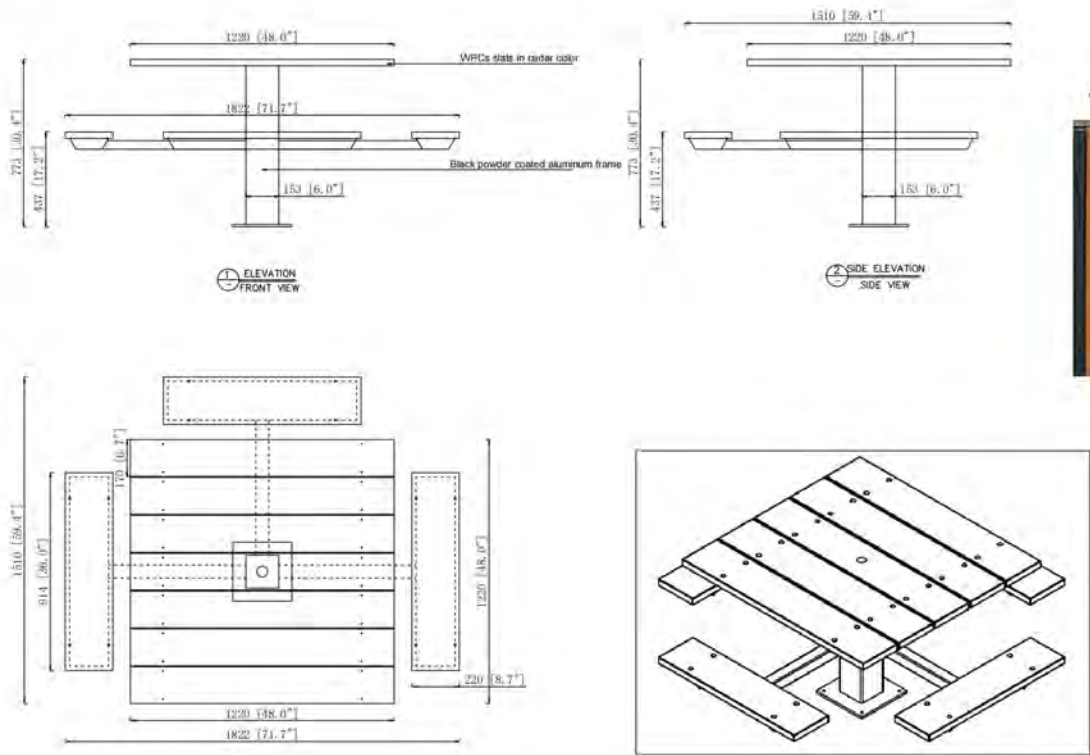

Total width: 183cm



Total depth: 151cm



Width of table top: 120cm



Depth of table top: 120cm

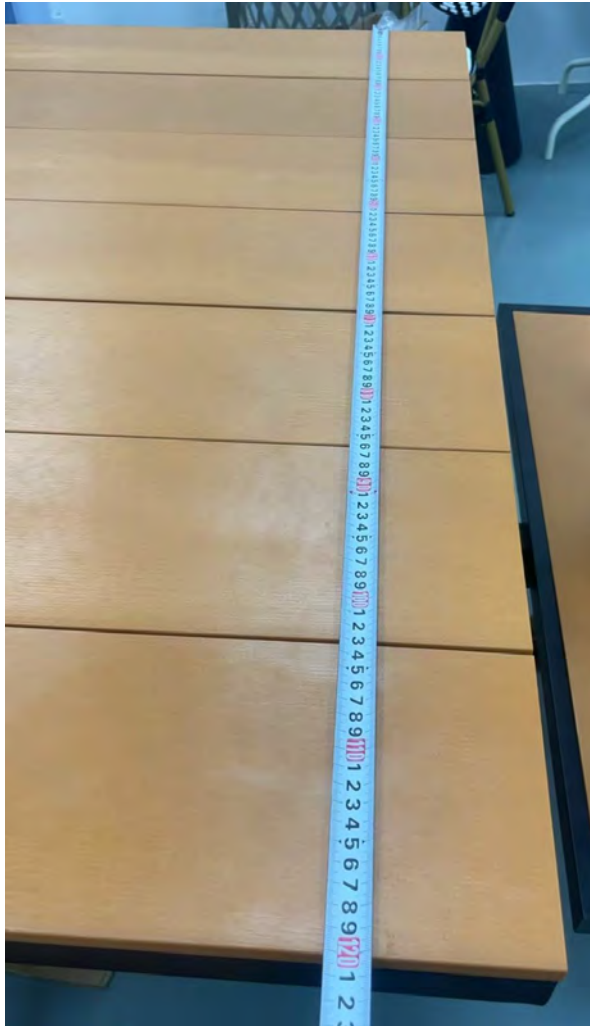

width of one wood slat: 17cm



width of bench: 22cm

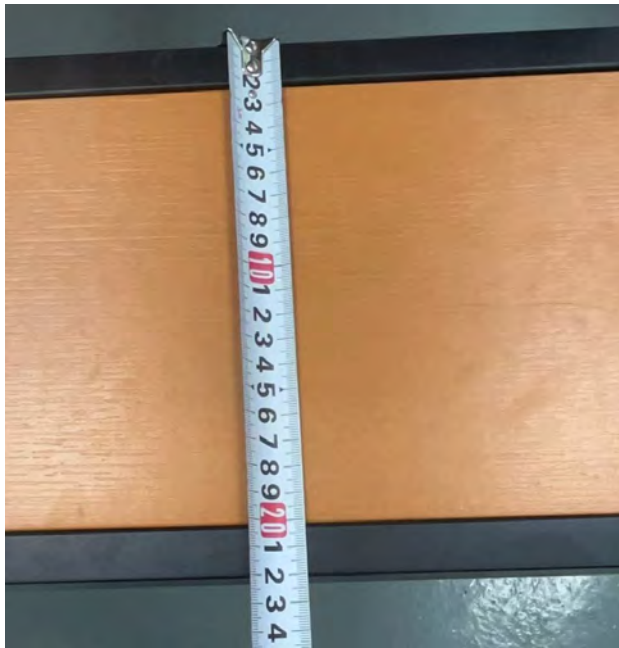

Length of bench: 91.4cm



Total Height: 77cm



# Inspection Report-O2-Outdoor Table

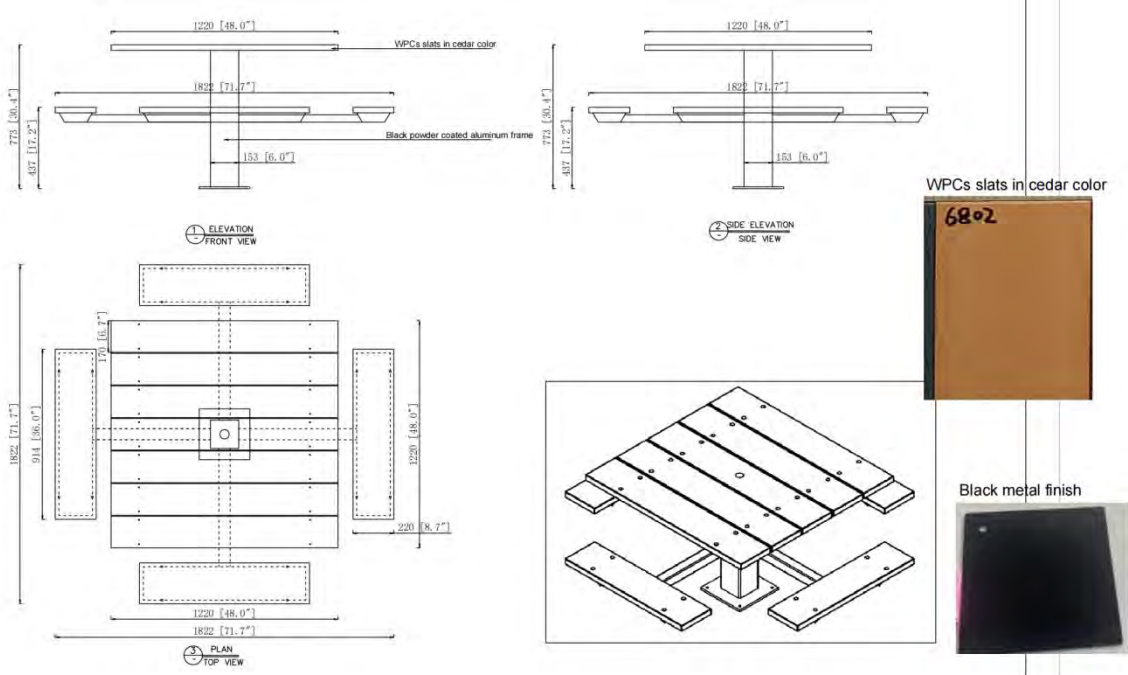







Depth of table top: 120cm

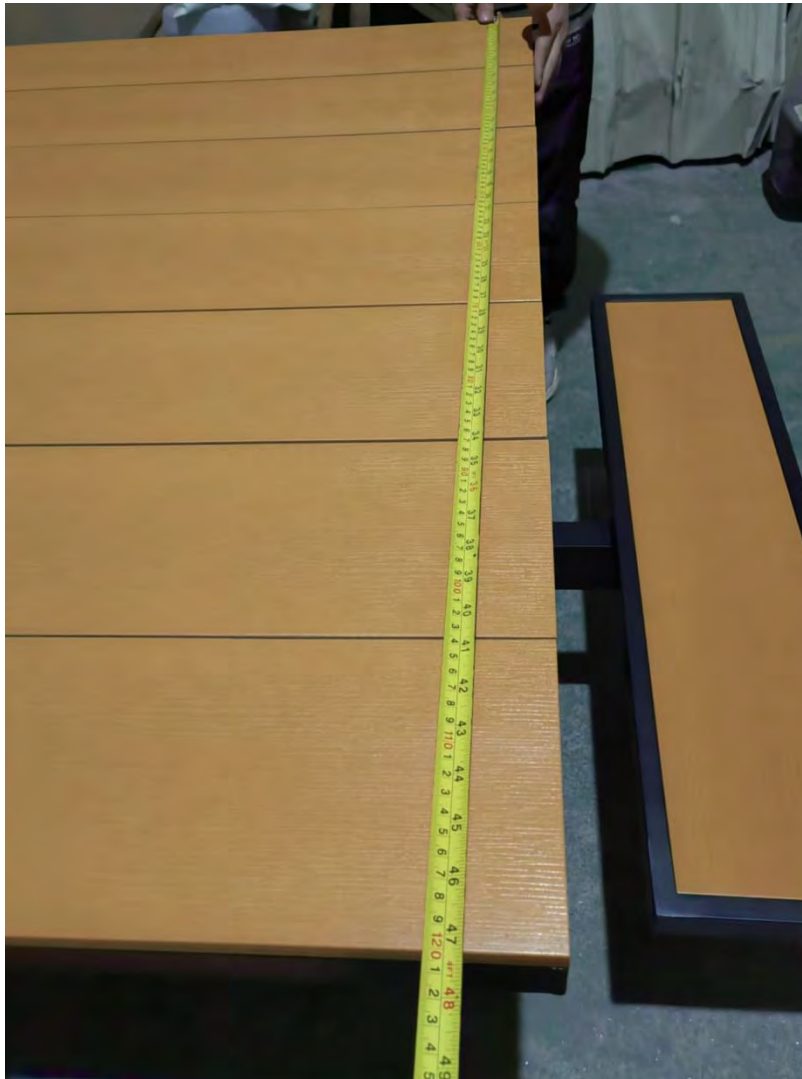



Width of table top: 120cm



width of one wood slat: 17cm

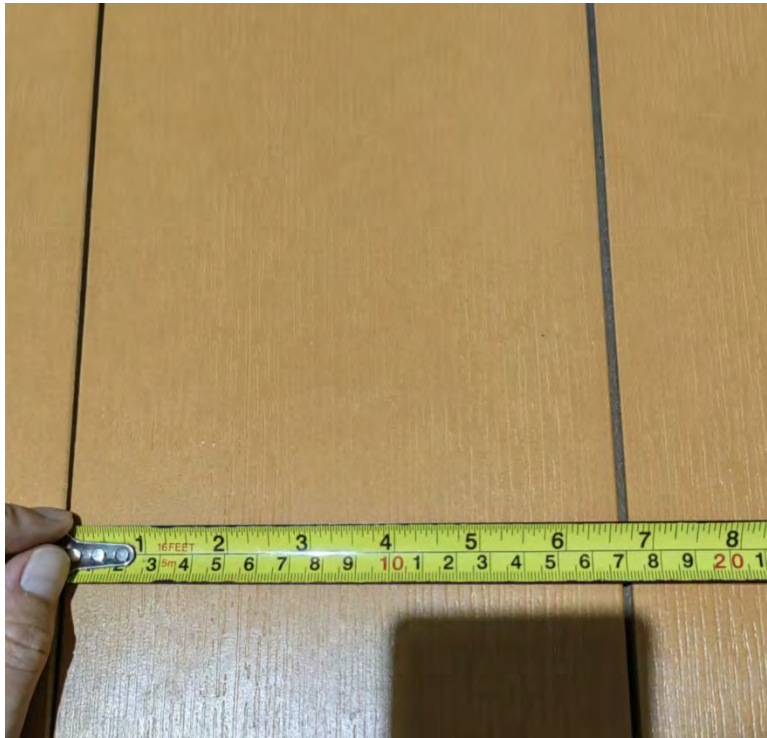

Total height: 77cm



width of bench: 22cm



height of bench: 43cm



Total width: 182.2cm

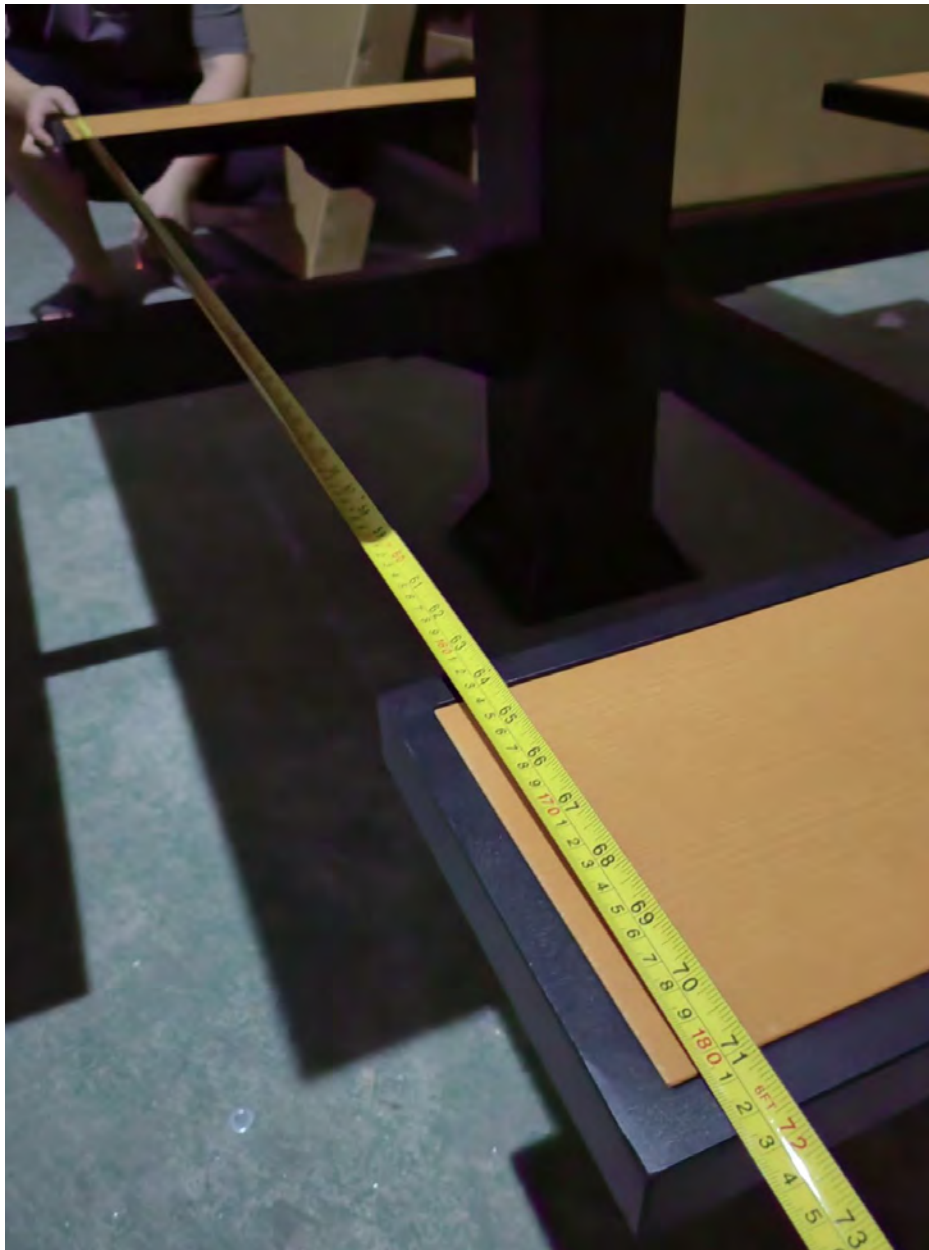

# Inspection Report-T2-Table

The locking casters shall be black, we are changing all the casters to black.



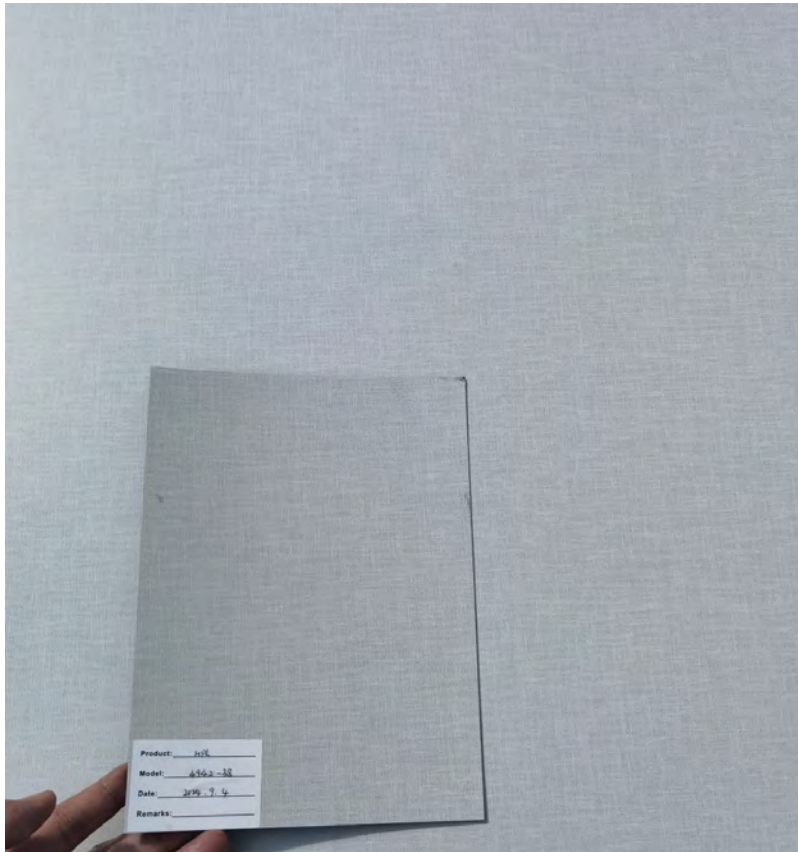





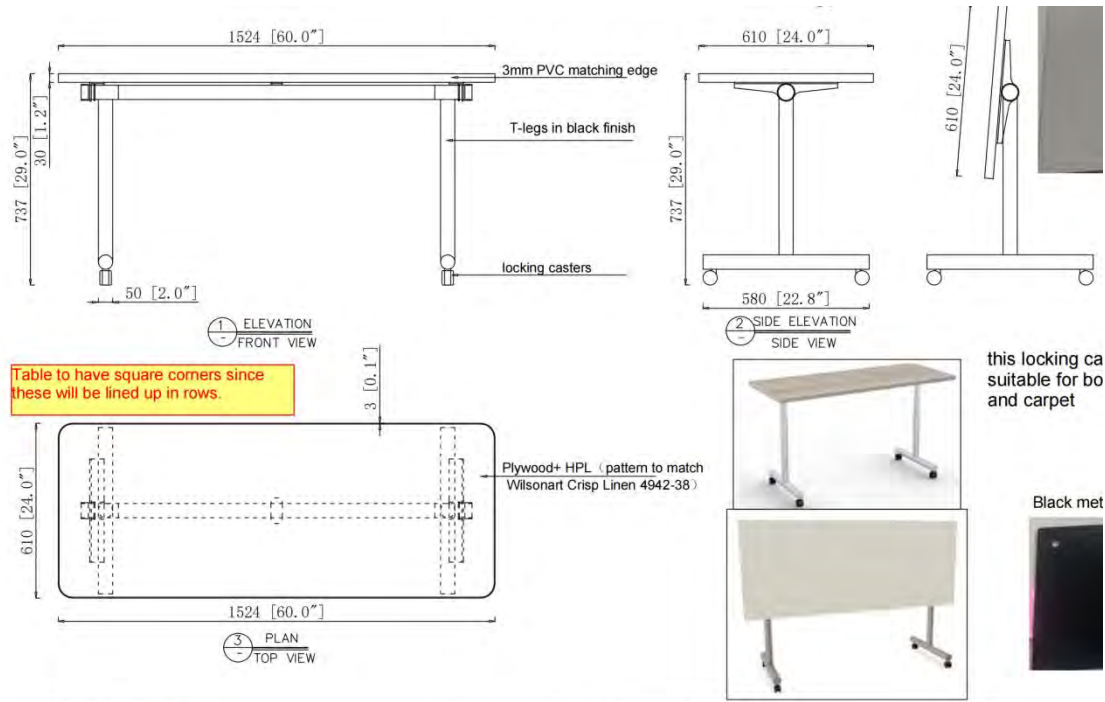

em Number: T2

Dimensions:60"W\* 24"D\*29"H

Product Name: Table

T-legs in black metal finish; locking casters

Width:152cm





Depth: 60.7cm





Thickness of table top: 3.2cm



Height: 73.7cm



T-leg Dia: 5cm



Inspection Report-T6-Table



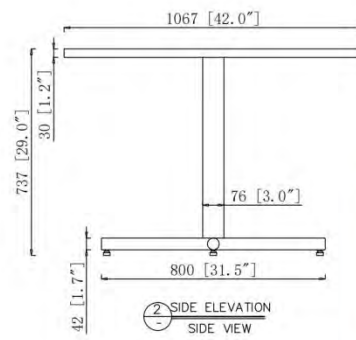
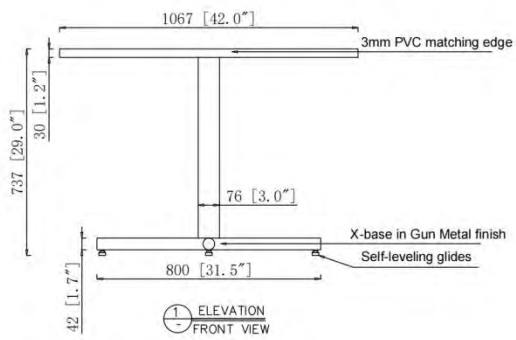

Self-leveling glides

HPL pattern to match  
Wilsonart Crisp Linen

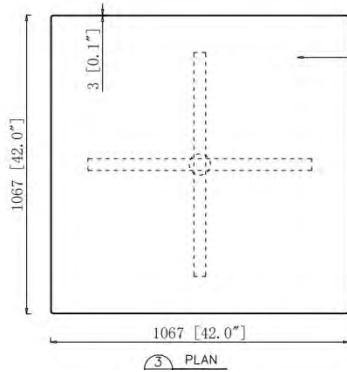

Plywood+ HPL (pattern to match  
Wilsonart Crisp Linen 4942-38)



Gunmetal finish



width: 106.7cm

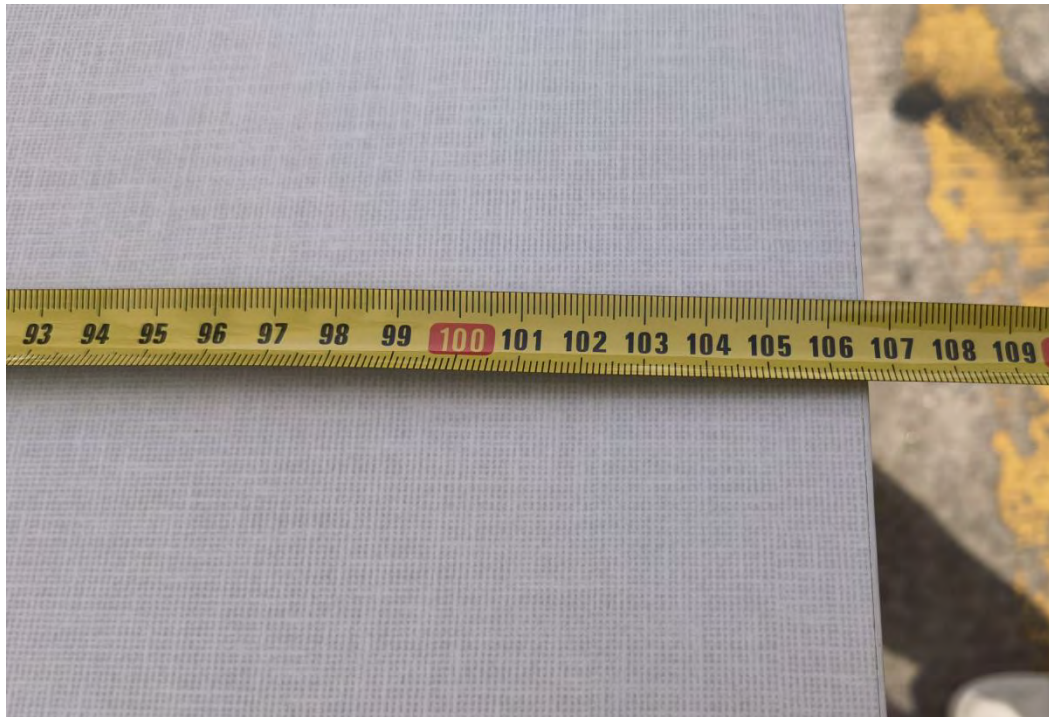

depth: 106.7cm



Height: 74.2cm



Leg width: 80cm



# Inspection Report-DIN-SG-02-Counter

## Stool





width: 53.5cm



depth: 54cm



height: 94.5cm



seat height: 62cm



arm height: 80cm



# Inspection Report-LOB-SG-02-Sofa





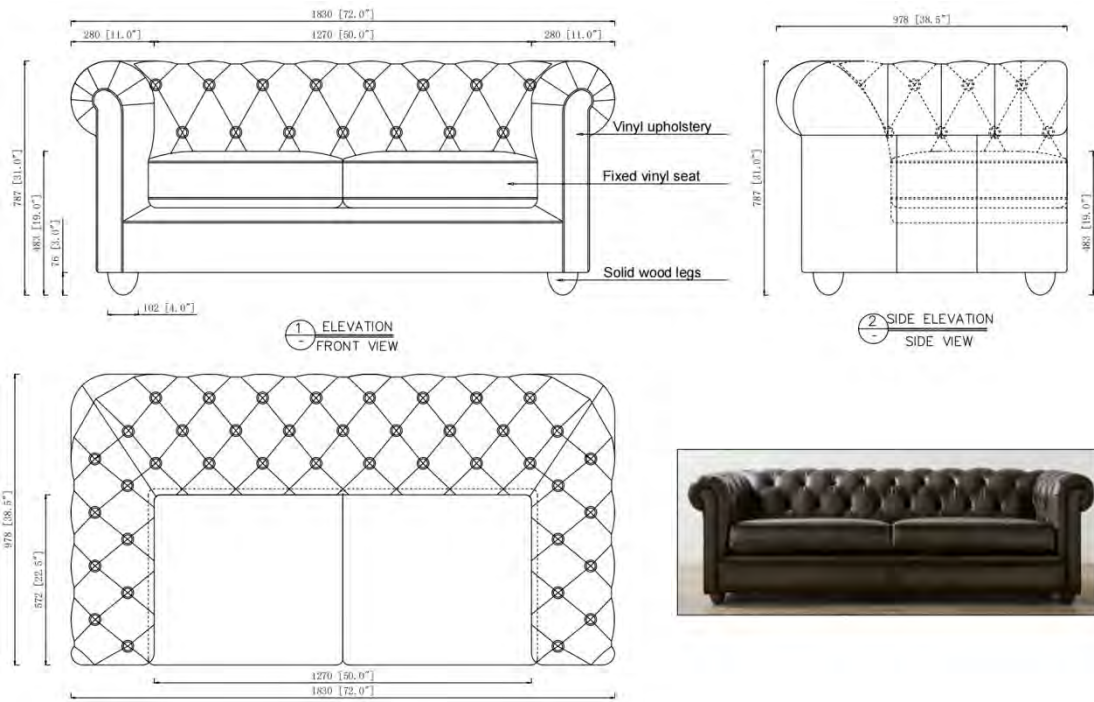

Width: 183cm



depth: 95cm



height: 79cm



seat height: 48cm



# Inspection Report-OFF-SG-04-Custom corner booth

(the actual vinyl color is deeper)









Height: 93cm



seat height: 51cm



Length of booth: 167.5cm



The width has been separated into 2 parts.

with of longer booth: 102cm



width of shorter booth: 65cm



seat depth: 49cm

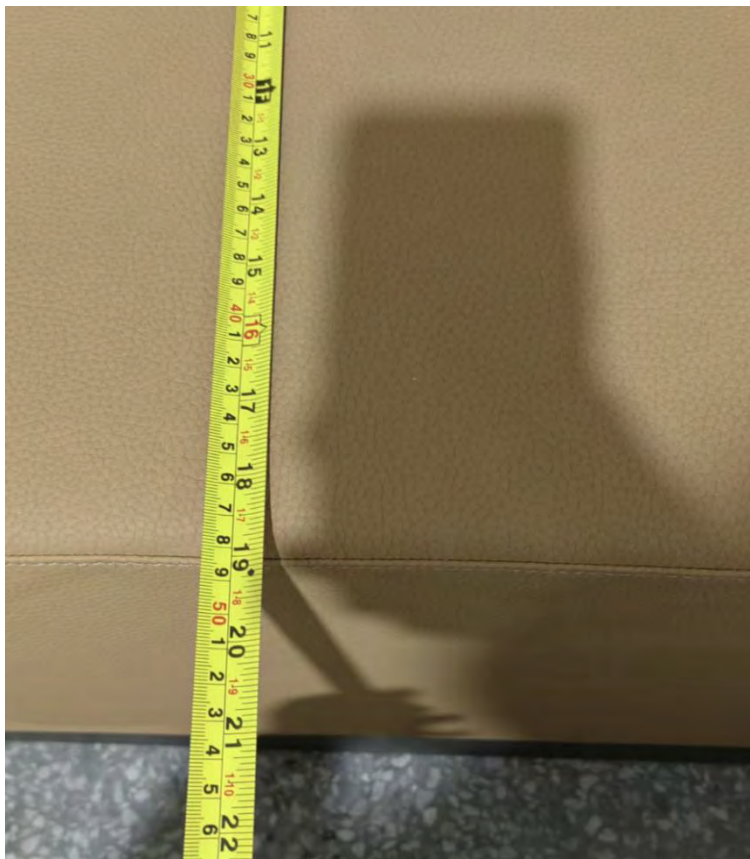

# Inspection Report-ROF-SG-01-Barstool



width: 58cm



seat height: 63cm



arm height: 79cm



depth: 58cm



## Inspection Report 质检报告

Item (产品)	Armless 17 SEATS	Inspector (质检员)	Tom	Factory(工厂)	
PO Number (订单号)	1152	Quantity (订单数量)	1 set	Quantity for inspection (抽检数量)	1 set
Stage (检验阶段)	Final	Date(日期)	2024.9.18	Inspection result (检验结果)	Passed
Inspection Detail(检验情况)					
Item(项目)	Detail(详细)	Inspection Standard (检验标准)	Status(情况)	Pictures (照片)	
Dimensions (refer to drawing) 尺寸(参考图纸)	L×W×H (长×宽×高)	*Tolerance is +/-10mm	Okay.	02-10	
	Critical Dimensions (重点尺寸)	*Tolerance is +/-10mm	None.		
	Others(其它)	*Tolerance is +/-10mm	Okay.		
Welding (焊接)	Welding strength (焊接强度)	*Full Welded *No Crack	Okay.		
	Grinding and polishing (打磨与抛光)	*Smooth *No Crack	Okay.		
	Color (颜色)	*Close the color sample	Okay.		
	Others (其它)		None.		
Coating (表面处理)	Cleaning(表面清洁)	*No Scratch *Clean *No Dents	Okay.		
	Others(其他)	*Square Test	Not yet.		
	Other		None.		
Installing (安装)	All of Screws and plastic (螺栓及塑料件)	*Tight	Okay.		
	Product Strength (产品强度)	*Loading Capacity is 40kgs.	Okay.		

	Function(产品功能)	*Steady *Sit Comfortable *Bumper Installed	Okay.	
	Others(其它)	*No Deformation *No Significant Defect	Not yet.	
Packaging (包装)	Product Protector (产品保护物)	*Bubble Film *PP BAG * Kraft paper	Not yet.	
	Ship mark(箱唛)	*Same as the customer requirement	Not yet.	
	Product Inserts (产品附件)	No Product Inserts	Not yet.	
	Others(其它)		Not yet.	
<b>Defects(缺陷)</b>				
No. (序号)	QTY (数量)	Solution(解决方法)		Pictures (图片)



01



02



03



04



05



06



07



08



09



10

# Inspection Report

Table





Table height: 74.5cm



Width: 160cm



Depth: 80cm



Leg width: 5cm



# Chair





Depth: 58cm



Height: 85cm



Width: 55cm





## Final INSPECTION REPORT

报告提交日期  
Report Date:

Mar.21.2023

检验报告提交:  
Inspected By:

Along

检验员:  
Inspection Performed:

Along

签样:  
Sample:

NO

检验时间:  
Inspection Date(s):

Mar.21.2023

装运时间:  
Shipment Date(s):

### P.O AND PRODUCT STATUS

订单号码 P.O Number	产品编号 Pattern Number	客户 Customer	产品描述 Product Description	订单数量 Order Qty	完成数量 Finished Product	包装比例 Packing Percent	整体结果 Overall Result	备注评论 Comments
SZ202204 25	GR-327		Vanity Shelf	47	47	100%	Pass	

By Signing and approving this drawmg, customer hereby releases the manufacturer and/or its representative, agent offers or employees from any and all liabilities daims that may arise from the installation and use of this product.

GR-327







**Load bearing test qualified**

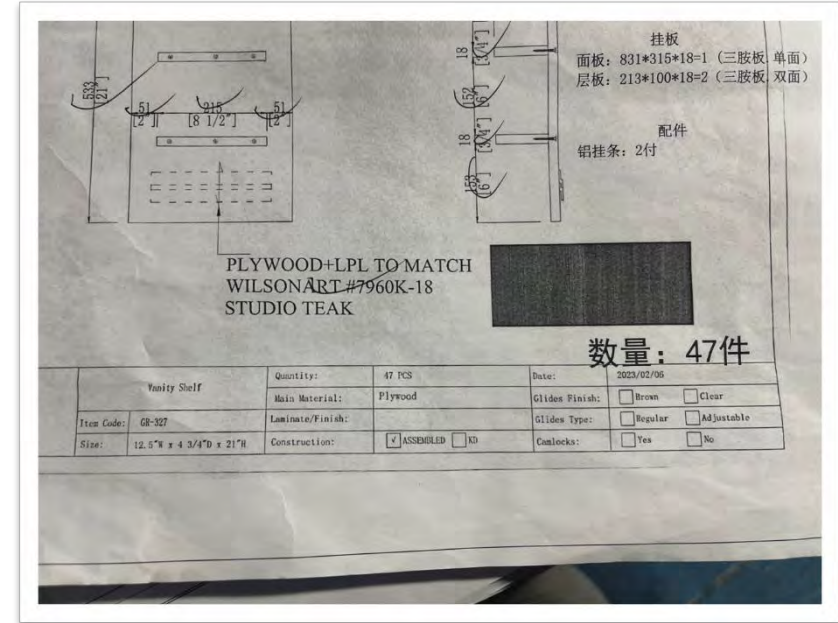
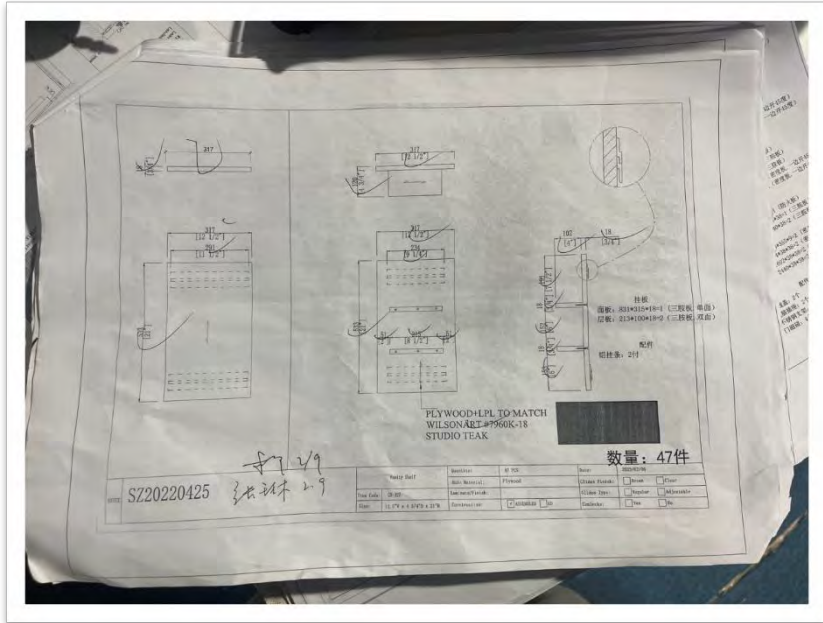

The size is the same as the drawing

## Inspection Report- Banquet Chair-1100 PCS









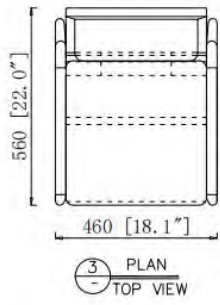
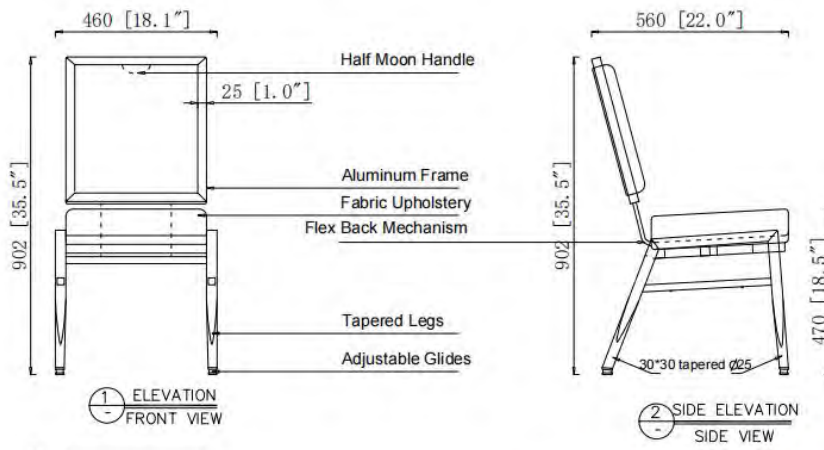

YF-01 fabric



BZ bronze powdercoat finish

Beige:  
Depth: 56cm



Width: 46cm



Height: 90cm

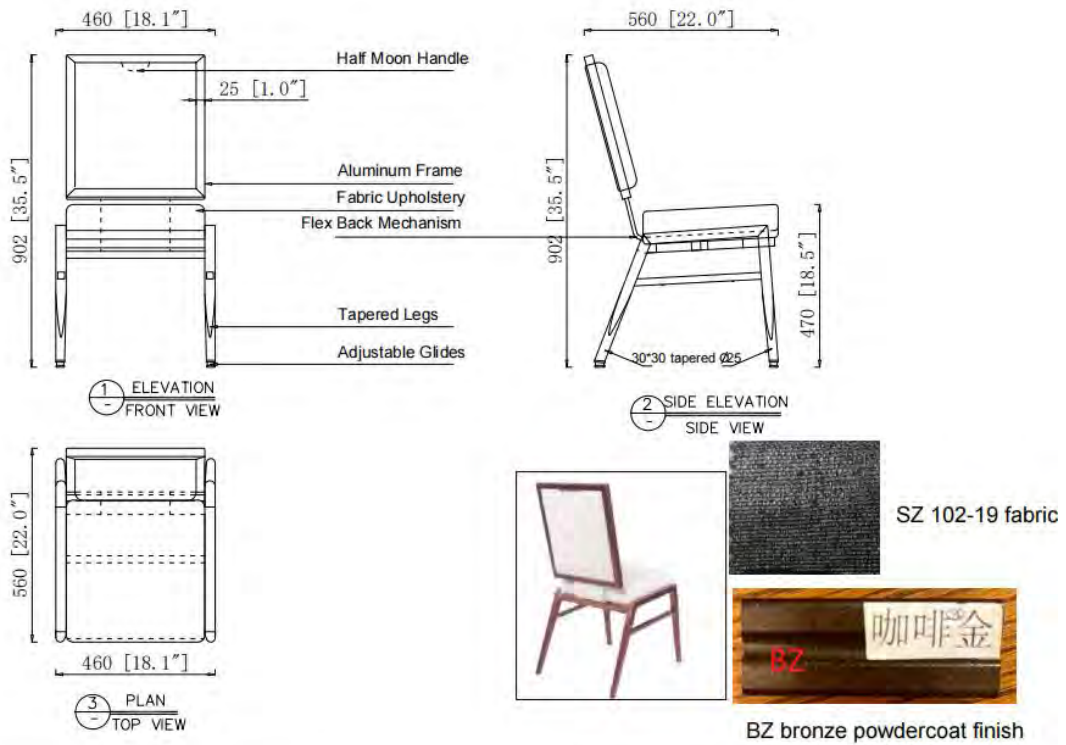

Gray:

Depth: 56cm



Width: 46cm



Height: 90cm



# Inspection Report

Item	Mailbox with post	Inspector	Jack	Factory	
PO Number		Quantity	150pcs	Quantity for inspection	8pcs
Stage	Final	Date	2025.1.24	Inspection result	Passed

## Inspection Detail

Item	Detail	Inspection Standard	Status	Pictures
Dimensions (refer to drawing)	L×W×H	*Tolerance is +/-10mm	Okay.	06-09, 21-26
	Critical Dimensions	*Tolerance is +/-10mm	None.	
	Others	*Tolerance is +/-10mm	Okay.	
Welding	Welding strength	*Full Welded *No Crack	Okay.	
	Grinding and polishing	*Smooth *No Crack	Okay.	
	Color	*Close the color sample	Okay.	
	Others		None.	
Coating	Cleaning	*No Scratch *Clean *No Dents	Okay.	
	Others	*Square Test	Not yet.	
	Other		None.	
Installing	All of Screws and plastic	*Tight	Okay.	
	Product Strength	*Loading Capacity is 40kgs.	Okay.	
	Function	*Steady *Sit Comfortable *Bumper Installed	Okay.	

	Others	*No Deformation *No Significant Defect	Not yet.	
Packaging	Product Protector	*Bubble Film *PP BAG * Kraft paper	Okay.	11-15, 18-20
	Ship mark	*Same as the customer requirement	Not yet.	
	Product Inserts	No Product Inserts	Not yet.	
	Others		Not yet.	
<b>Defects</b>				
No.	QTY	Solution		Pictures



01



02



03



04



05



06



07



08



09



10



11



12



13



14



15



16



17



18



19



20



21



22



23



24



25



26

# Inspection Report-Lounge Chair



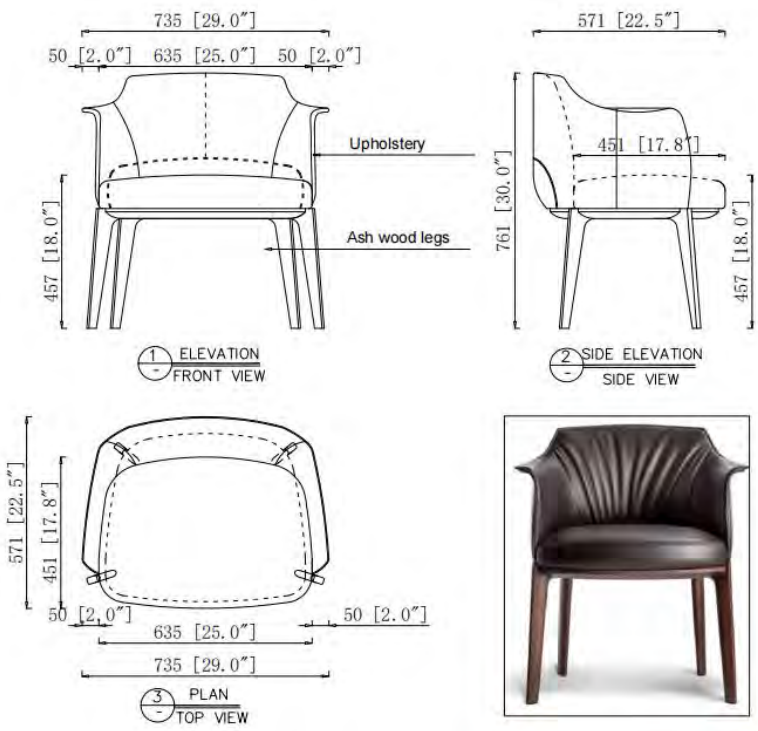

Width: 73.5cm



Depth: 57cm



Height: 78cm

